

Motor Type	L	L1	L2	L3	L4	L5	h	H	H1	B	b	n-d	TWt. (kg)	Base NO.
Y280M-2/90KW	1682	162	910	1510	300	1065	190	755	440	550	15	4-Ø26	822	23A-30
Y280S-2/75KW	1632	162	910	1510	300	1015	190	755	440	550	15	4-Ø26	767	23A-30
Y160M-4/11KW	1230	105	750	1160	220	613	115	680	365	400	12	4-Ø17.5	291	13A-90

Notes: Cone tube is out of scope of supply

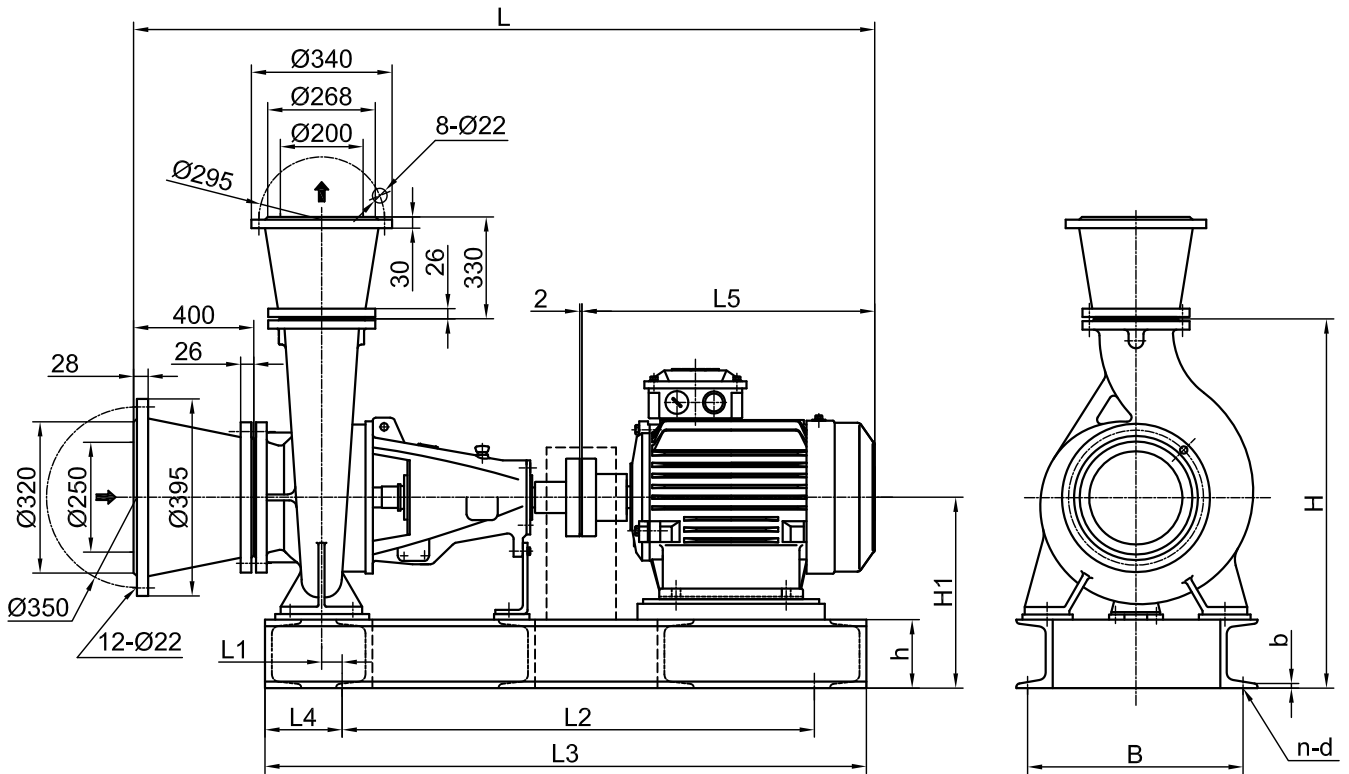

Pump wt. = 106Kg

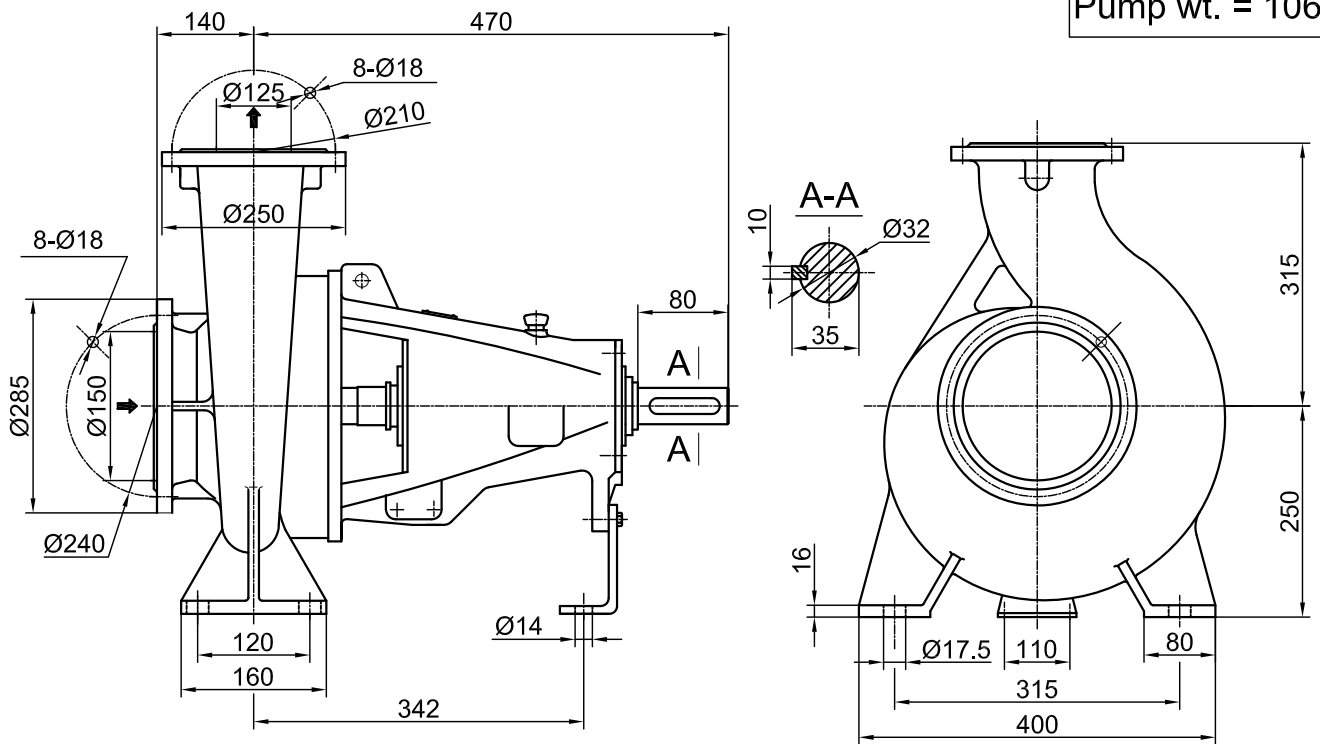

Rotation clockwise viewing from the driving end.

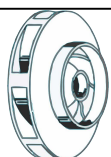

**INFINITYFLO**  
PUMPS (PTY) LTD

General Arrangement Drawing

SXA125/20

- PROPOSALS
- PURCHASE
- AS BUILT