

Motor Type	L	L1	L2	L3	L4	L5	h	H	H1	B	b	n-d	TWt. (kg)	Base NO.
Y180L-4/22KW	1342	104	750	1160	220	725	115	720	365	400	12	4-Ø17.5	377	13B-70
Y180M-4/18.5KW	1302	104	750	1160	220	685	115	720	365	400	12	4-Ø17.5	359	13B-70

Notes: Cone tube is out of scope of supply

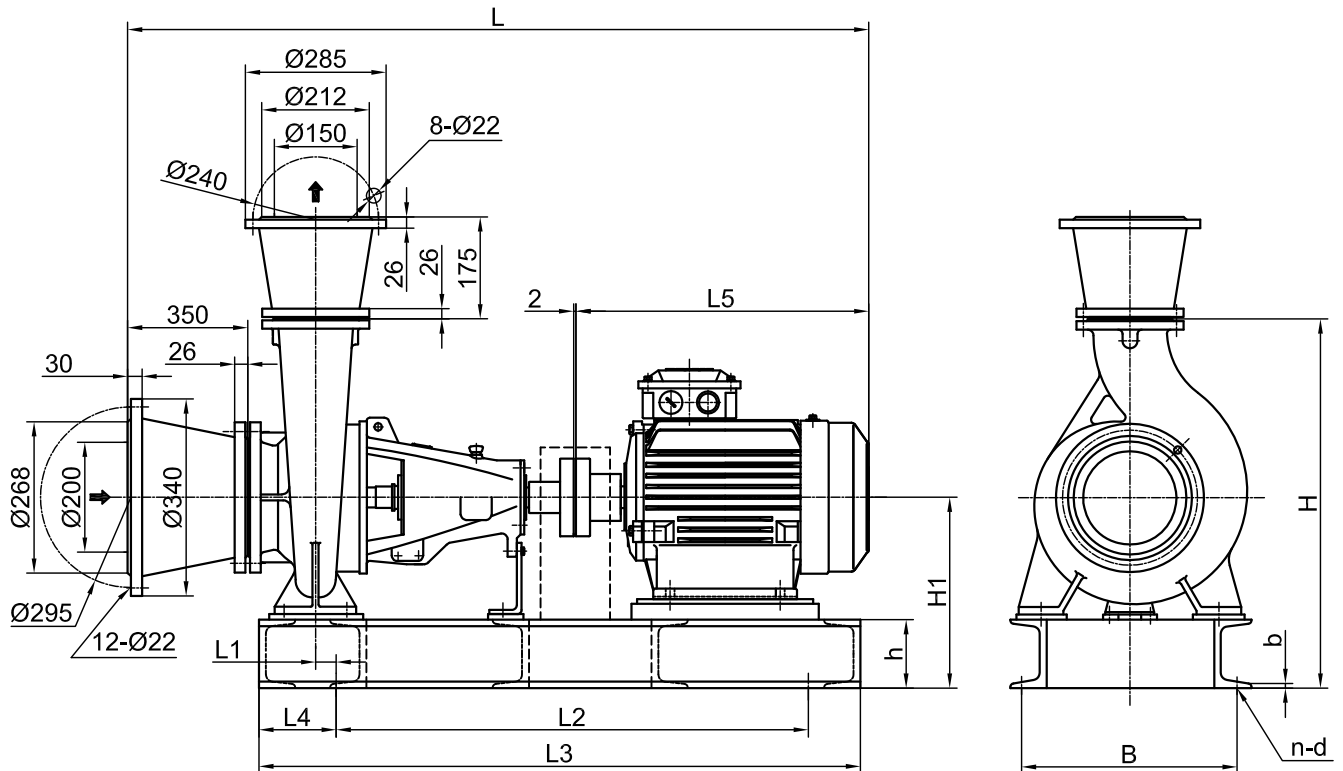

Pump wt. = 115Kg

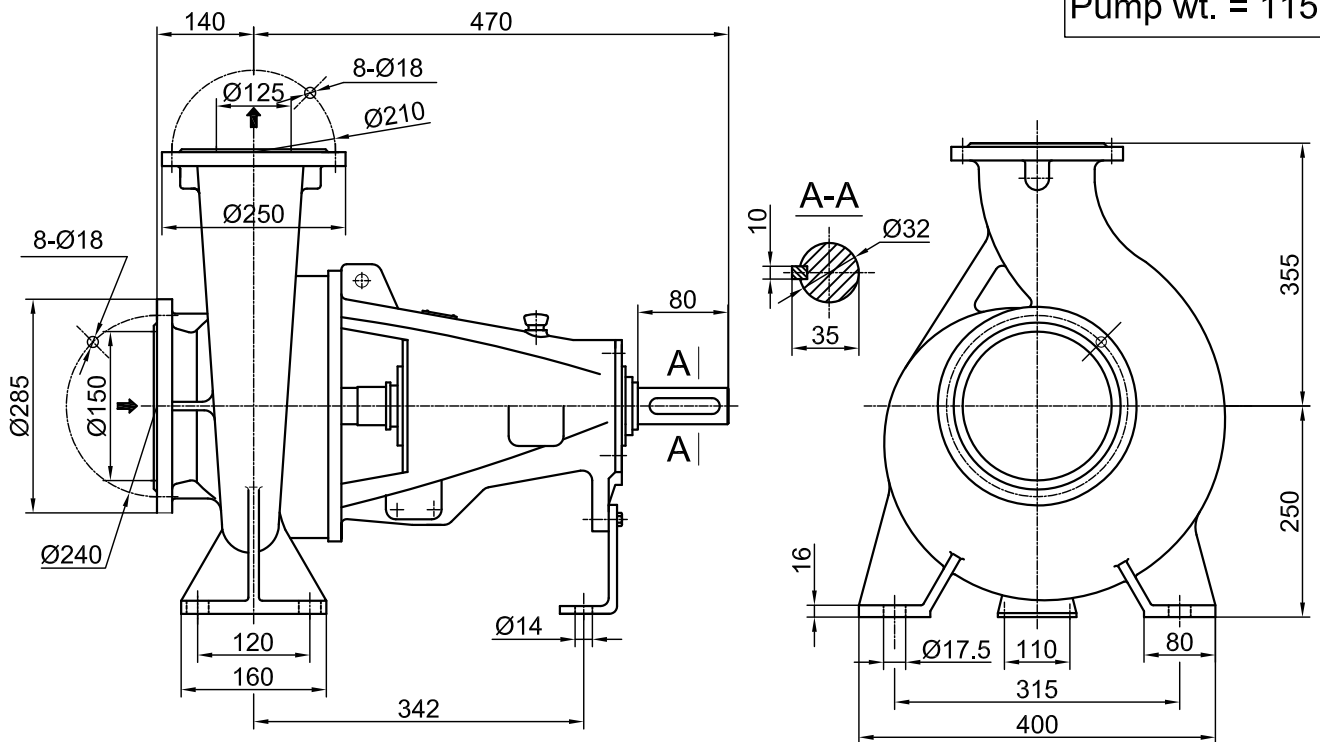

Rotation clockwise viewing from the driving end.

	General Arrangement Drawing	<input checked="" type="checkbox"/> PROPOSALS
	<p style="text-align: center;">SX A125/26</p>	<input type="checkbox"/> PURCHASE <input type="checkbox"/> AS BUILT