

Motor Type	L	L1	L2	L3	L4	L5	h	H	H1	B	b	n-d	TWt. (kg)	Base NO.
Y250M-4/55KW	1651	150	870	1390	260	948	160	840	440	550	15	4-Ø26	702	20A-30
Y225M-4/45KW	1566	140	820	1320	250	863	160	840	440	550	15	4-Ø26	625	18A-55
Y225S-4/37KW	1541	140	820	1320	250	838	160	840	440	550	15	4-Ø26	590	18A-55

Notes: Cone tube is out of scope of supply

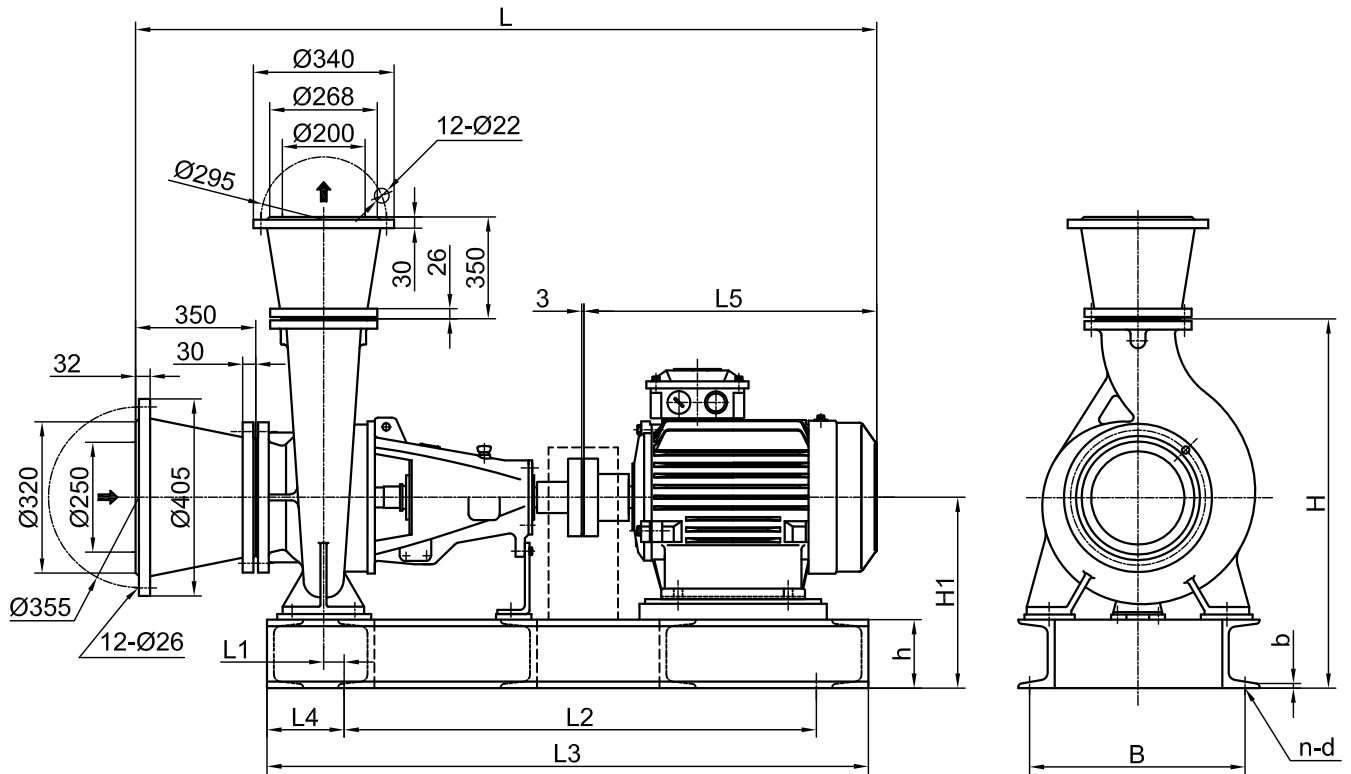

Pump wt. = 170Kg

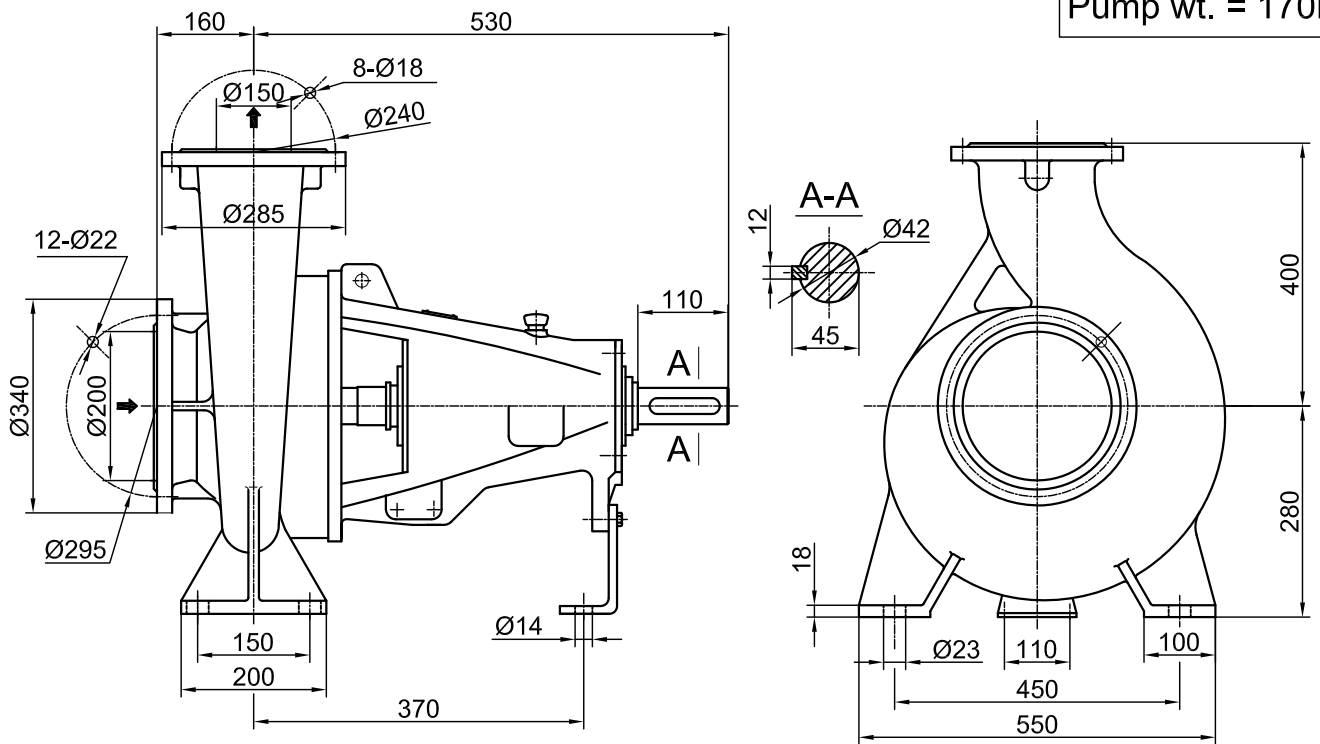

Rotation clockwise viewing from the driving end.



INFINITYFLO
PUMPS (PTY) LTD

General Arrangement Drawing

SXA150/32

- PROPOSALS
- PURCHASE
- AS BUILT