

Motor Type	L	L1	L2	L3	L4	L5	h	H	H1	B	b	n-d	TWt. (kg)	Base NO.
Y315M2-4/160KW	2176	180	1140	1780	320	1270	165	1125	565	620	15	4-Ø28	1685	28A-85
Y315M1-4/132KW	2176	180	1140	1780	320	1270	165	1125	565	620	15	4-Ø28	1605	28A-85
Y315S-4/110KW	2176	180	1140	1780	320	1220	165	1125	565	620	15	4-Ø28	1455	28A-85
Y280M-4/90KW	1956	171	1040	1675	320	1050	165	1125	565	620	15	4-Ø28	1145	28B-120

Notes: Cone tube is out of scope of supply

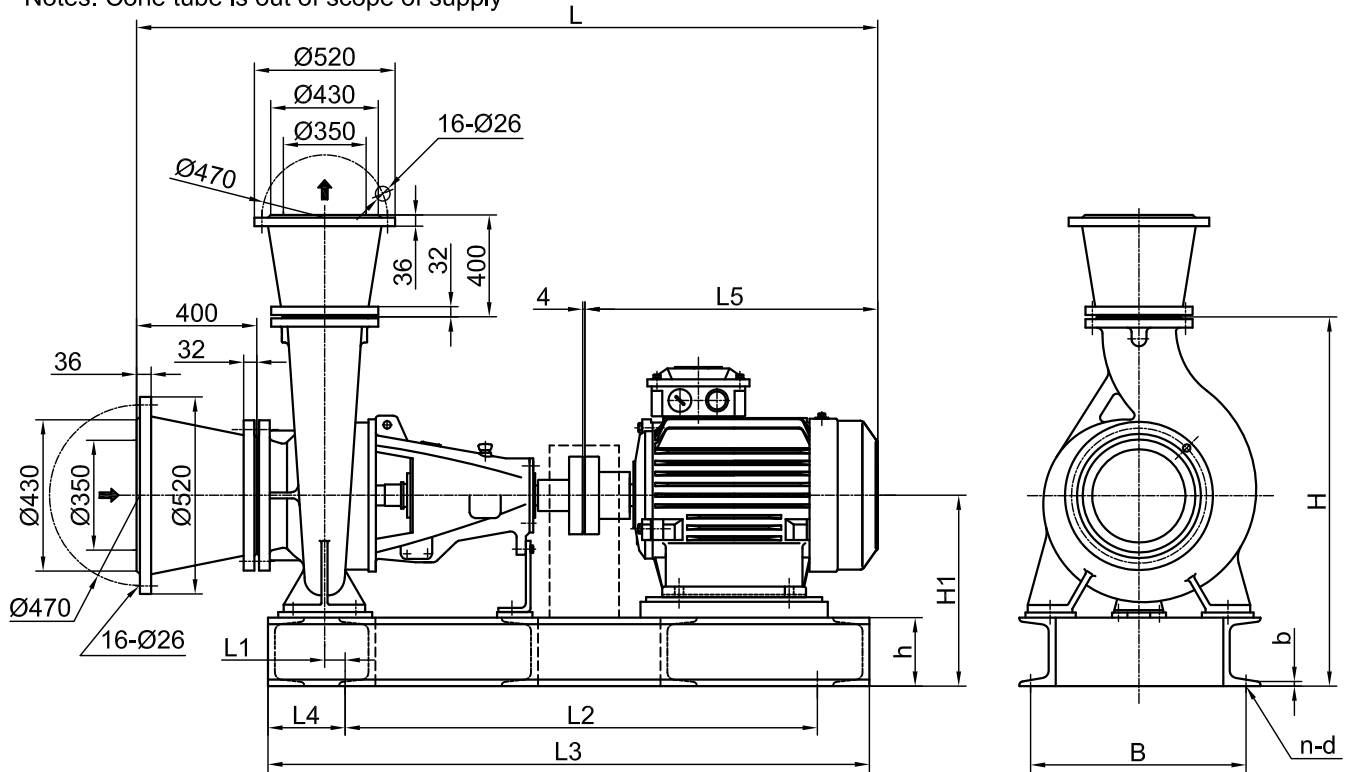

Pump wt. = 390Kg

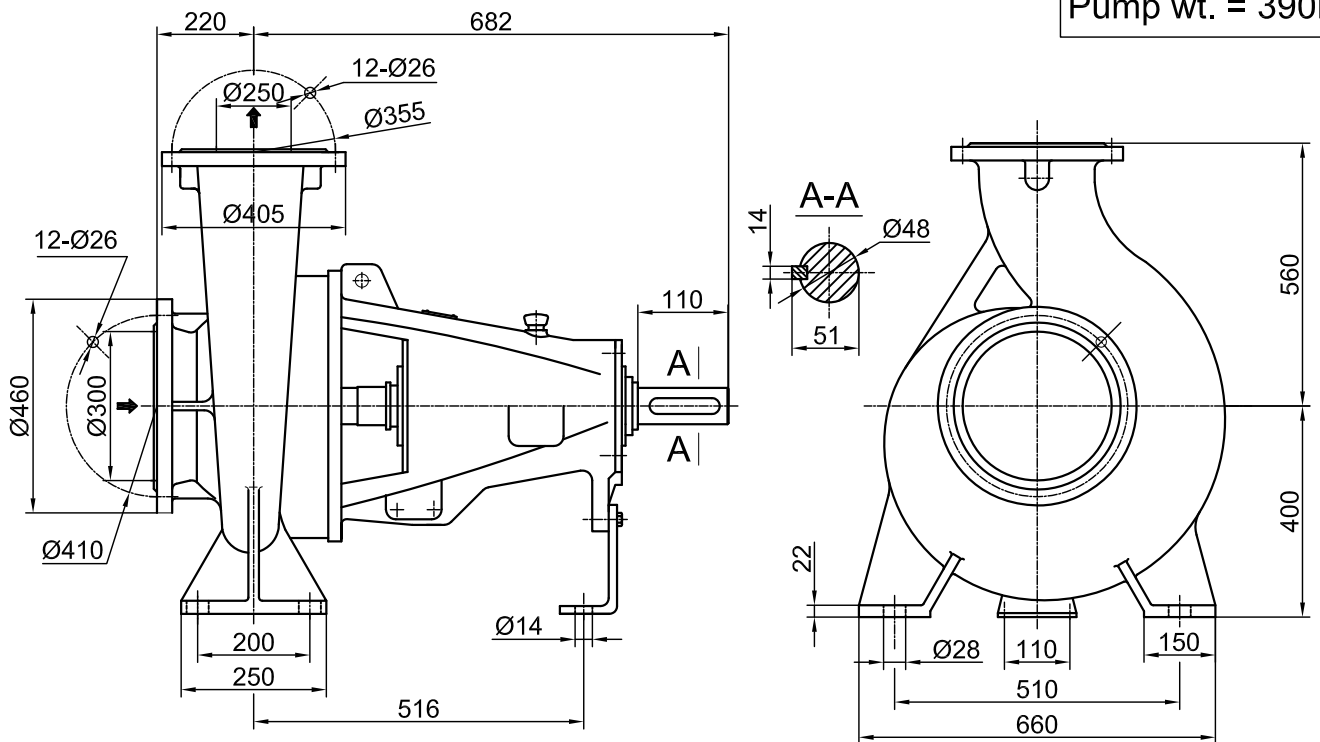

Rotation clockwise viewing from the driving end.

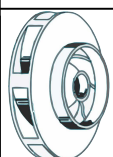

**INFINITYFLO**  
PUMPS (PTY) LTD

General Arrangement Drawing

SXA250/40

- PROPOSALS
- PURCHASE
- AS BUILT